

Mar - May 2025

INDIAN STONE



A journal from
the Federation
of Indian Granite
& Stone Industry

PRECISION TOOLS, POLISHED GROWTH

Advanced cutting & diamond
tools are helping shape the
Indian stone industry

News, articles
& musings on

Stone industry

STONA Fair

Skill development

Sustainability

Spotlight on stars



FIGSI Office Bearers at the 305th Executive Committee meeting at Hyderabad on June 2, 2025.

30 YEARS
OF EXCELLENCE



1st
TIME MADE IN INDIA

THIN MULTI WIRE

MACHINE FOR MARBLE BLOCK CUTTING
DF-2000 & DT-2000

Unmatched 0.5mm cut accuracy



SHRI BHAGWATI MACHINES PVT. LTD.

END-TO-END TURNKEY SOLUTIONS INNOVATIVE SOLUTIONS GLOBAL REACH ROBUST GLOBAL SUPPLY CHAIN ENHANCED EFFICIENCY 24/7 SERVICE

sales.smd@bhagwatomachines.com | CONTACT US :- +91 8690131999 | Follow Us On | Visit Us : www.bhagwatomachines.com

G-179 Makhupura Extension Parbatpura, Makhupura Industrial Area, Ajmer, Rajasthan 305002



Indian Stone

An in-house journal of FIGSI.
Mar - May 2025 Edition

Editorial Board

Chairman

Anuj Modi

Deputy Chairman

Deepak Ajmera

Members

Ishwinder Singh
N Ashoken
Dr Harpal Singh Yadav
Arun Malhotra
K Keshava Murthy
N Mahesh
Arshaan Anees
S Shankaranarayanan
Harshinder Singh
Yusuf Kamal Khan

Co-ordinator

Flt Lt PUB Sharma (Retd)

Editor

MN Subramaniam

Graphic & Designing

PrintPedia

Digital Marketing

Harshinder Singh
Arshad Pasha

Office Bearers

2024-26

President

S Krishna Prasad

Vice Presidents

N Ashoken
Sunder Somani
Kalit Bhandari
Dr Harpal Singh Yadav
Guru Shastrimath
Arun Malhotra

General Secretary

Manoj Kumar Singh

Treasurer

Pramod Bhandari

Joint Treasurer

S Shankaranarayanan

Joint Secretaries

Sanjeev Modi
Laxmikant Jain
Manish Poddar
Ajitha Joy
Zaki Chakkiwala
Kailash Singh Mertiya
Pankaj Verma
Jameel Ahmed CH

Federation of Indian Granite and Stone Industry

"STONA", #429/7, 12th Cross, Sadashivanagar, Bengaluru - 560080, India
Ph: +91-8023612541

Email: figsi@figsi.in, stona@figsi.in

Website: www.figsi.in, www.stonaindia.co.in



Scan the QR code to
visit the FIGSI site
and digital hub.



Scan this QR code
to explore the digital
version of this magazine

CONTENTS

FROM FIGSI'S CHAMBERS

- 01 From the President's desk
- 02 Message from the General Secretary
- 03 Note from Chairman of Editorial board
- 04 304th Executive Committee Meeting
- 06 FIGSI delegation visits ACE Micromatics
- 07 Telangana chapter felicitates Office Bearers
- 08 305th Executive Committee Meeting
- 10 FIGSI registered for CSR activities
- 11 Industry Interactions
- 12 Site Registration
- 13 Industry updates in news
- 13 Advertise in Indian Stone magazine

POLICY & INDUSTRY INTERACTIONS

PG 11 & 12



STONE FAIR UPDATES

- 15 President leads FIGSI delegation to 16th Xiamen Stone Fair, China



SKILL CENTRE NEWS & UPDATES



Skill Review Meeting held in Hosur on 26th March 202517

Progress report by FIGSI Skill Sub Committee Chairman16

Visit to Chamarajnagar by FIGSI and SCMS ...18

NSDC visit to Jaipur Center for Stone Excellence ...19

POLICY DEVELOPMENTS



28

Vice President N Ashoken on shifting global business dynamics

INDUSTRY GEMS

Saluting **Shri R Sethuram**, founder of The Bharat Granites Pvt Ltd ... 24



OTHERS

- 26 Deep Dive EXIM data
- 31 Article on Bhagwati Machines
- 36 Business news
- 38 Industry news
- 39 Important notifications
- 43 Concert at a quarry
- 44 Obituary
- 46 Stone facts and quiz

EXPERT VIEW

Sandhya Raghunandan from Red Graniti Quarries & Blocks India Pvt Ltd, Bengaluru writes about 'India's rise in machinery & technology from Europe to self-reliance'34



FROM THE PRESIDENT'S DESK



Dear Friends,

Firstly, I thank our Prime Minister Sri. Narendra Modi ji and the Indian government and our Esteemed Armed forces for the success of operation Sindoor, the war against Terror.

I am happy to note that in Andhra Pradesh the Cabinet has approved the Reforms in the Minor Mineral Policy which is a big relief for the Minor Minerals and MSME in the State of Andhra Pradesh.

The Karnataka government, Ministry of Mines and Geology successfully implemented fully ONLINE payments in Integrated lease Management System (ILMS), which is helpful in ease of doing business.

Supreme court NGT case, regarding environmental clearances for below 5 hectares is still going on and we are expecting a favourable judgement shortly which will benefit the entire Mining sector.

FIGSI is also working closely with related ministries on the Supreme court Judgement DT.16/5/2025 on ex post facto EC grant orders as many of the quarries are affected and closed in most of the states.

Our INTEGRATED SKILL & RESEARCH CENTERS at Hosur, Tamil Nadu and Jaipur, Rajasthan are operational and the courses offered are as follows:

1. Accounts executive – Import & Export
2. Digital Marketing
3. Computer Numerical Controller (CNC)
4. Mining Mate
5. Stone Processing Machine Operator

FIGSI is working with Skill Council for Mining Sector (SCMS) / National Skill Development Council (NSDC) / Ministry of Skill Development and Entrepreneurship (MSDE). Joint proposal with SCMS on skill delivery target for south India mining sector

of the tune of 10,000 numbers for Karnataka, AP, Telangana and Tamil Nadu for the year 2025-26 is submitted. FIGSI along with SCMS representatives visited Chamarajnagar, Karnataka to get the first-hand information about the skilling requirements of the industry.

I am happy to Inform that we are closely working with state NSDC for local inspections in Karnataka, AP, Telangana and Tamilnadu and also apprising NSDC Delhi for target allocations.

A delegation led by me visited ACE Micromatics on 1st Apr 2025, who manufacture the CNC Machines and CNC Simulators. We are working with them for CNC skill delivery association.

Thank You!!!

S Krishna Prasad
President

MESSAGE FROM THE GENERAL SECRETARY



Dear members,

Warm Greetings to all of you!!!!!!

At the outset, I would like to express our deepest condolences to the families affected by the recent air tragedy in Ahmedabad – one of the most devastating incidents in Indian aviation history. Our thoughts and prayers are with the bereaved families in this difficult time.

Heartiest Congratulations to Shri R. Veeramani Ji !

On behalf of the entire FIGSI fraternity, we extend our warmest congratulations to Shri R. Veeramani, Founder President of FIGSI, on being elected as Vice Chairman of CAPEXIL and Chairman of the Natural Stone and Products Panel.

This prestigious appointment is a proud moment for all of us at FIGSI. With over five decades of exemplary service and visionary leadership in the stone sector, Shri Veeramani Ji has been a pillar of strength and inspiration. His election is not only a recognition of his outstanding contribution but also a testament to the values and standards.

Proud moment for FIGSI – Proud moment for the Indian stone industry!

The 305th Executive Committee Meeting held in Hyderabad was a resounding success. It was heartening to see enthusiastic participation and vibrant discussions after a long interval.

I'm pleased to share that FIGSI's membership has now crossed 1,600, with many more expressing interests in joining our growing fraternity. This is a reflection of our collective efforts and the value that FIGSI continues to offer to the natural stone industry.

In a significant development, FIGSI successfully availed the "Vivaad Se Vishwas" scheme of the

Government of India and has resolved its long-standing Income Tax matter through a one-time settlement.

To further international outreach, the FIGSI team participated in the Xiamen International Fair, actively promoting STONA 2027 on the global stage.

Another milestone achievement is that FIGSI is now officially registered for CSR (Corporate Social Responsibility). This opens avenues to receive CSR funding and contribute meaningfully to the development and welfare of the industry.

We are proud to announce that our esteemed member, Sri Rajendra Maheswari ji, has been elected as the President of Laghu Udyog Bharati, Bagru, Rajasthan. This is a moment of great pride for the entire FIGSI family.

Lastly, I extend heartfelt congratulations to Sri Saurabh Bhasin, son of Smt. Raj Bhasin, on his remarkable journey towards conquering the Seven Summits. His recent ascent of Mount Everest in May 2025, following his earlier triumphs including Aconcagua, marks his sixth successful climb – a truly inspiring feat.

Let us continue to support and celebrate one another as we move forward with unity and purpose.

Thank you.
Warm regards,

Manoj Kumar Singh
General Secretary

CHAIRMAN OF EDITORIAL BOARD



Dear readers,

I hope this STONA edition of Indian Stone finds you in great spirits!

We're thrilled to bring you an issue brimming with insights, stories, and visuals straight from one of the world's most prominent stone fairs.

This edition offers a panoramic view of the Indian stone industry's current momentum, showcasing not only the energy of sector but also the many forces shaping the future of our industry.

Inside, you'll find:

- Key updates from recent Executive Committee meetings, giving you a front-row seat to the latest decisions and direction
- Deep dives into advanced tools and machinery that are driving efficiency and transformation across our industry
- Stories highlighting the remarkable progress of India's stone sector, both in scale and innovation
- Inspiring updates from the global stone community, including a celebration of Gems of the Stone Industry

As earlier, the new content sections are arranged by color-coded bands for easy navigation:

- Brown: FIGSI news and announcements
- Blue: All things STONA
- Maroon: Updates from the Centre for Stone Excellence
- Gray: Industry features and market insights
- Green: Sustainability and environmental innovation

For greater accessibility, Indian Stone is now available in a fully digital, mobile-friendly format on the FIGSI website, so you can stay connected anytime, anywhere.

It's a privilege to serve such a dynamic industry and to help document its growth, ideas, and people.

On behalf of the entire editorial committee, thank you for your continued support, and please don't hesitate to send us your feedback or ideas for future editions.

Warm regards,

Anuj Modi
Chairman, Magazine Sub Committee



Scan this QR code to explore the digital version of this magazine or the past few editions.

304TH EC MEETING

Term 2024-26



304th EC meeting held on 25th March 2025 at Taj Vivanta Yeshwanthpur Bengaluru. Seen from L to R are Shri Madan Lal Jangid, Chairman STONA 2025, Shri Sunder Somani, Vice President, Shri Ishwinder Singh IPP, Shri Manoj Kumar Singh, General Secretary, Shri S Krishna Prasad, President, Shri R Veeramani, Founder President, Shri Gurushastrimath, Vice President, Shri Kalit Bhandari, Vice President and Shri Harpal Singh Yadav, Vice President.

304th Executive Committee meet

25.03.2025 | Bengaluru

The 304th Executive Committee meeting of FIGSI was held at Taj Vivanta, Bengaluru. This meeting marked another important milestone in FIGSI's journey of institutional strengthening and industry leadership.

Led by FIGSI President Sri S Krishna Prasad, the meeting saw robust participation from members, with productive discussions across key focus areas. Sub-committee heads also presented detailed updates.



Above: Shri. Manoj Kumar Singh, General Secretary speaking at the 304th EC meeting held on 25 March 2025. Left: Shri Madan Lal Jangid Chairman STONA 2025 addressing the gathering at the EC meeting.

304TH EC MEETING Term 2024-26



Shri R Shiv Kumar, Executive Committee member felicitating Shri Madan Lal Jangid, Chairman STONA 2025.



Shri N Mahesh EC member making his point at the 304th EC meeting held on 25th March 2025.



Shri. Rajesh Angara EC member making his point at the 304th EC meeting held on 25th March 2025.



304th EC meeting in progress on 25th March 2025 at Taj Vivanta, Bengaluru.

INDUSTRY INTERACTIONS

FIGSI President leads delegation visit to ACE Micromatics



Left: FIGSI delegation visit to Ace Micromatic led by Shri S Krishna Prasad President FIGSI. Seen in the Picture are Shri Gurushastrimath Vice President FIGSI, Shri P U B Sharma C E O FIGSI and Ms. Sandhya Raghunandhan. Pictures of the CNC machines of Ace Micromatic are also attached. Right: FIGSI delegation meeting at Ace Micromatic on 11-04-2025.



FELICITATION 305TH EC Meeting, Hyderabad

Telangana Chapter felicitates FIGSI Office Bearers



Shri R Veeramani Founder President FIGSI felicitated by Telangana Chapter at the 305th EC meeting held in Hyderabad.



Shri Manoj Kumar Singh General Secretary, FIGSI felicitated by Telangana Chapter.



Shri Ishwinder Singh Imm. Past President FIGSI felicitated by Telangana Chapter.



Shri Gurushastrimath Vice President FIGSI felicitated by Telangana Chapter at the 305th EC meeting.



Shri. Naresh Chand Pareek Advisor FIGSI felicitated by Telangana Chapter.



Shri N Ashoken Vice President FIGSI felicitated by Telangana Chapter.

305TH EC MEETING

Term 2024-26



EC members stand for the National Anthem at the 305th Executive Committee meeting in Hyderabad on June 2, 2025.

305th Executive Committee meet



Shri Gurushastrimath Vice President FIGSI addressing the 305th EC meeting in Hyderabad on 02-06-2025.

02.06.2025 | Hyderabad



Shri R Veeramani, Founder President FIGSI addressing the 305th EC meeting.



Shri Ishwinder Singh Imm. Past President FIGSI speaking at the 305th EC meeting in Hyderabad on 02-06-2025.

305TH EC MEETING Term 2024-26



Shri K Keshava Murthy EC member FIGSI raising the point the Q&A session.



Shri R Shivakumar EC member raising the point the Q&A session at the 305th EC meeting in Hyderabad.



Shri. CS Rao, EC member raising the point at the Q&A session at the 305th EC meeting in Hyderabad.



Shri. Manoj Kumar Singh, General Secretary FIGSI proposing the vote of thanks at the 305th EC meeting.



Group photo of Executive Committee members at the 305th EC meeting in Hyderabad on 02-06-2025.

FIGSI Registered for Undertaking CSR Activities



We are pleased to share a significant milestone in FIGSI's institutional journey. The Federation of Indian Granite and Stone Industry (FIGSI) has officially received approval from the Ministry of Corporate Affairs, Government of India, for registration under entities eligible to undertake Corporate Social Responsibility (CSR) activities.

As per the approval letter dated 4th June 2025, issued by the Office of the Registrar of Companies (ROC-Delhi), FIGSI is now recognized as a registered entity authorized to participate in CSR initiatives. The CSR registration number is CSR00092976, and members are encouraged to refer to this number for any related communication or documentation.

This registration not only strengthens FIGSI's commitment to social impact but also opens new opportunities for collaborative CSR projects within the stone industry. It paves the way for the Federation to partner with companies fulfilling their CSR mandates while contributing to community development, sustainability, and skill-building efforts in our sector. For further queries or participation in FIGSI-led CSR initiatives, please contact the secretariat.

Corporate Social Responsibility in India

Corporate social responsibility (CSR, also called corporate conscience, corporate citizenship, social performance, or sustainable responsible business/ Responsible Business is a form of corporate self-regulation integrated into a business model.

The term corporate social responsibility came into common use in the late 1960s and early 1970s. ISO 26000 is the recognized international standard for CSR.

Evolution of CSR in India

JRD Tata was instrumental in conducting the first social audit in India. Since its inception, the Tata and Steel Company has been a shining example of social responsibility.

CSR helps to assist socially and economically weaker sections of the society, It also assures stakeholders that the company is sensitized toward enhancing the quality of life, economic well-being of the society.

In India, Corporate Social Responsibility (CSR) is regulated by the Companies Act, 2013. Companies meeting certain financial criteria (net worth of ₹500 crore or more, turnover of ₹1,000 crore or more, or net profit of ₹5 crore or more) must spend at least 2% of their average net profit from the preceding three years on CSR activities.

To receive CSR funds, NGOs, trusts, societies, and Section 8 companies need to be registered under Indian laws, have a track record of at least three years in social impact work, and register with the NGO DARPAN portal and file Form CSR-1.



INDUSTRY INTERACTIONS

FIGSI delegation visits Helios Stones factory in Hyderabad



Visit of FIGSI delegation to Helios Stones factory in Hyderabad on 02-06-2025. Left: Seen in the picture from L – R are Shri Yusuf Kamal Khan EC member FIGSI, Shri N Ashoken Vice President FIGSI, Shri Hari Mohan Sharma EC member FIGSI and Shri Neelesh Chavan EC member FIGSI.

Shri Arun Yogiraj visits stone factory at Jaipur

Shri Arun Yogiraj, eminent sculptor visited EC member Shri Hari Mohan Sharma's factory at Jaipur on 13th April 2025. Shri Yogiraj is an honorary member of FIGSI.



Meet with Hon'ble Chief Minister of Uttar Pradesh

Shri R Shivakumar EC member FIGSI met Hon'ble Chief Minister of Uttar Pradesh Shri Yogi Adityanath on 14th April 2025 at Lucknow.

INDUSTRY INTERACTIONS

Founder President Shri Veeramani meets Hon'ble Tamil Nadu CM

FIGSI Founder President Shri R Veeramani met Hon'ble Chief Minister of Tamil Nadu Shri Stalin. Hon'ble CM of Tamil Nadu assured to meet him separately to discuss Tamil Nadu Granite Industry problems and develop Granite Industry in Tamil Nadu.



Meet with Attorney-General of India

Shri N Mahesh, Executive Committee Member, FIGSI with Attorney-General of India, Shri R Venkataramani. The Attorney General for India is the chief legal advisor of the Government of India. Shri R Venkataramani is the incumbent Attorney General for India. He succeeded to the office as the 16th Attorney General on 1 October 2022. His predecessor was Shri KK Venugopal.

SITE REGISTRATION COMPLETE

FIGSI ITI Site Registration process completed on 23-05-2025 and balance payment received.



Industry updates from the news

उदयपुर: 5 हजार करोड़ का व्यापार होगा प्रभावित, भारत में करीब 14 लाख टन मार्बल का आयात मार्बल व्यवसायियों ने तुर्की से तोड़ा व्यापारिक संबंध

एक्सक्लूसिव

मोहम्मद इलियास
patrika.com

उदयपुर भारत और पाकिस्तान के मध्य तनाव के हालात के बीच पाकिस्तान का साथ देने पर उदयपुर को मार्बल मंडी ने तुर्की से व्यापारिक संबंध तोड़ दिए हैं। एशिया की सबसे बड़ी मार्बल मंडी उदयपुर के व्यापारी अब तुर्की से कोई मार्बल आयात नहीं करेंगे। तुर्की से भारत करीब 14 लाख टन मार्बल आयात किया जाता है। इनमें से अकेले उदयपुर का करीब पांच हजार करोड़ का व्यापार सालाना है। उदयपुर मार्बल प्रोसेसर समिति ने समस्त मार्बल व्यापारियों से तुर्की का माल नहीं खरीदने की अपील की।

तुर्की से आता है 14 लाख टन मार्बल

तुर्की से पूरे हिन्दुस्तान में करीब 14 लाख टन मार्बल आयात किया जाता है। उदयपुर मार्बल प्रोसेसर समिति के महासचिव हितेश पटेल ने बताया कि अभी उदयपुर में 50 से भी ज्यादा बड़े उद्योगी तुर्की मार्बल आयात कर रहे हैं, जो कई हजार टन हैं। तुर्की ने भारत के खिलाफ जारी हथकड़ी का साथ दिया। ऐसी स्थिति में सभी व्यापारियों ने एक साथ एक रयत लेकर तुर्की से मार्बल आयात करने पर स्वेचिक्क बहिष्कार किया।

अग्रिम आदेश तक कोई माल आयात नहीं

एशिया की सबसे बड़ी मार्बल निर्यात मंडी की प्रमुख संख्या ने राष्ट्रहित में तुर्की के खिलाफ संपूर्ण व्यापारिक संबंध खत्म कर दिए हैं। अग्रिम आदेश तक उदयपुर बंद से कोई माल आयात नहीं करेंगे। **कपिल सुराणा**, उदयपुर मार्बल प्रोसेसर समिति अध्यक्ष

प्रधानमंत्री को लिखा पत्र

उदयपुर मार्बल प्रोसेसर समिति ने इस संबंध में प्रधानमंत्री को पत्र प्रेषित कर तुर्की के खिलाफ लिए फैसले के बारे में बताया। समिति ने निर्यात किया कि भारत सरकार की ओर से तुर्की के साथ-साथ राष्ट्रहित में विश्व के किसी भी देश के खिलाफ कोई भी कड़ा कदम उठाया जाता है तो उदयपुर मार्बल प्रोसेसर समिति सरकार के हर निर्णय का पूरा ताम्बन्ह करेगी।

Operation Sindoor was conducted by the Indian Army during the recent days. During the Indo-Pak tensions Asia's biggest Marble Center which is located in Udaipur decided to boycott Turkey due to the support given by Turkey to Pakistan. It supported the Indian Government in this regard and also wrote a letter to this effect to the Hon'ble Prime Minister Shri Narendra Modi-Ji wherein any Nation which supported anti national activities against India would be boycotted.

जयपुर

लघु उद्योग भारती की वीकेआई इकाई का गठन, दीपक अग्रवाल बने सचिव



लघु उद्योग भारती की कार्यकारिणी घोषित



ब्यूरो नवज्योति/उदयपुर: लघु उद्योग भारती के प्रांत महामंत्री प्रवीण गुप्ता ने उदयपुर महानगर सहित विभिन्न इकाइयों की नई कार्यकारिणियों की घोषणा की। आयोजन के दौरान पर्यवेक्षक हसमुख पंड्या, प्रदेश उपाध्यक्ष रीना राठौड़, प्रांत उपाध्यक्ष राकेश वर्डिया, प्रदेश कार्यकारी सदस्य महेंद्र माडावत और निवर्तमान अध्यक्ष मनोज जोशी उपस्थित थे।

निवर्तमान अध्यक्ष मनोज जोशी ने बताया कि किस प्रकार मात्र 150 सदस्यों से बढ़कर संगठन की सदस्य संख्या 750 हो गई है। प्रदेश मॉडिया प्रमुख तरुण दवे ने बताया कि उदयपुर महानगर इकाई अध्यक्ष राजेंद्र सुराणा, सचिव शुभम डांगी, कोषाध्यक्ष अनिला कटारिया, उपाध्यक्ष मुकेश तलेसरा व कलित भंडारी मनोनीत हुए। इसी तरह कलड़वास इकाई अध्यक्ष बाबूसिंह राजपुरोहित, सचिव मुकेश मुणोत, कोषाध्यक्ष दिनेश शर्मा, देवेश, मादड़ी इकाई अध्यक्ष सुशिम सिंघवी, सचिव अरविंद मोहंता, कोषाध्यक्ष आशीष मित्तल, सुखर इकाई अध्यक्ष विजय गोधा, उपाध्यक्ष मुकेश सिन्हा, दीपक जैन, सचिव हिमांशु मेहता, कोषाध्यक्ष नीरज शर्मा, गुडलो इकाई अध्यक्ष दीपक हरकावत, सचिव हर्ष जिंदल, कोषाध्यक्ष कुलवंत सिंह, गिवा इकाई अध्यक्ष ओम दवे, सचिव प्रखिल समर और कोषाध्यक्ष गौरव मारू मनोनीत हुए। इसी तरह महिला इकाई अध्यक्ष सीमा पारीक, सचिव रेखा रानी जैन, अहिल्या बाई होलकर महिला इकाई अध्यक्ष ऋषिका पानेरी, सचिव आरुषि गोयल, कोषाध्यक्ष मोनिका कोठारी मनोनीत हुईं।

Advertise to an elite industry readership via Indian Stone magazine

ADVERTISEMENT TARIFF OF INDIAN STONE MAGAZINE

(Advt. tariff from 01.04.2021)

PARTICULARS	ONE INSERTION	SIX INSERTION (will be charged only for five insertion)	SIZE (ADVT)
Inside front/ back in colour	Rs.15,000/-	Rs.75,000/-	21 x 29.7 cm
One page colour	Rs.10,000/-	Rs. 50,000/-	21 x 29.7 cm
Half page colour	Rs.5,000/-	Rs. 25,000/-	21 x 14.5 cm
Quarter page colour	Rs.2,500/-	Rs. 12,500/-	11 x 14.5 cm

+ Applicable GST 18% extra

We are also introducing a page for classifieds (wanted/sale) for the benefit of members who want to buy a particular product or to sell their product. The tariff is Rs.2,000/- per classified. The size of this classified advertisement is 9 cm x 4.5 cm.

Fill this form to give your advertisement



Or email us at figsi@figsi.in. Our team will be in touch.



Thank you for being a part of STONA 2025.



Scan to share your feedback about the exhibition.

See you all in February 2027.



The mega stone exhibition on everyone's calendar

Stone in the spotlight



Quarry owners to mine experts



Architects & designers



Tool & machine manufacturers



FIGSI GOES GLOBAL XIAMEN, CHINA



President leads FIGSI delegation to 16th Xiamen Stone Fair, China

FIGSI delegation visit to XIAMEN from 16th to 19th March 2025. Seen in the picture above are Shri S Krishna Prasad President FIGSI and Shri Gurushastrimath Vice President FIGSI. Also seen is Shri. Naresh Pareekh Advisor, FIGSI.

Xiamen Fair & City Snapshot

The Xiamen Stone Fair is said to feature over 2,000 exhibitors. It showcases a wide range of natural stones, engineered materials, tools, and machinery.

Xiamen, a coastal city in southeast China, is a major stone processing and export hub, responsible for a significant share of China's stone exports.



REPORT FROM THE SKILL SUB COMMITTEE CHAIRMAN



Dear members and valued readers,

It gives me great pleasure to share updates from our Skill Development Centres.

In just the last two months, we've seen admissions cross the 50+ mark for the new programs due to begin from July. This is a strong signal that our training programs are gaining momentum and trust among youth.

Earning the trust of the talented youth of our country is key to the long-term growth of our skilling initiative.

I'm also proud to share that 7 candidates from the current batch have already been placed with various companies in the industry. This reaffirms our belief that with the right training, our young workforce is ready to contribute meaningfully to the growth of the stone sector.

It is also a sign of growing industry confidence in the skill centres. A couple of months ago our Skill Centre also received a Certificate of Appreciation from Pacific Quartz Surfaces for our exceptional skill training efforts.

In another positive development, we've also launched admissions for a new course: Stone Processing Machine Operator. This addition comes in direct response to industry feedback and will help address the specific manpower needs of processing units.

Looking ahead, the skilling initiative is well on its way to become a key driver of the industry ecosystem. Our aim is not just to train, but also to connect students, businesses, and institutions.

First movers are already reaping the benefits of our initiatives. I once again invite more companies to engage with us, be it through placements, guest lectures, short internships, or even helping shape course content.

Your involvement will further help align our training with the real needs of the industry.

With the Hosur Centre now operational and Jaipur's training expanding rapidly, we are on the right path to strengthening the workforce and ensuring sustainable growth for the stone industry.

I thank all stakeholders for their continued support. Together, let us make skill development the cornerstone of a stronger, more capable Indian stone industry.

Warm regards,

Ishwinder Singh
Chairman,
Skill Development Sub Committee

Scan this QR code to learn more and register your interest in partnering with and hiring from the Centres for Stone Excellence.



HOSUR SKILL CENTRE

FIGSI delegation visits Hosur Centre

On 26th March 2025, a FIGSI delegation visited the Skill Development Centre at Hosur to review ongoing progress and developments at the facility. The visit was led by Shri S Krishna Prasad, FIGSI President, and Shri Ishwinder Singh, Immediate Past President, and other Executive Committee members.

Members interacted with trainees, and assessed the infrastructure and training modules being implemented at the Centre. A review meeting was also held, where updates, challenges, and future plans for the Centre were discussed.



FIGSI delegation visited Hosur on 26 March, 2025 to over-see the developments at the skill development centre at Hosur. Seen in the picture are Shri S Krishna Prasad, President FIGSI and Shri Ishwinder Singh, Immediate Past President FIGSI.



Classes under progress at the Hosur Centre.



A view of EC members during the meeting at Hosur.



Visit to Chamrajanagar stone cluster



Shri Sudarshan Bellamkondi, Senior Manager Training, Delivery & Industry, State Engagement, Skill Council for Mining Sector visited the Chamrajanagar cluster. Seen along with him are Shri GM Hegde, FIGSI, Shri Guru Shastrimath, Vice President FIGSI, Shri Yusuf Kamal Khan, EC Member, FIGSI at KUM Internationals.

Also in some photos with him are Shri Jameel Ahmed, Joint Secretary, FIGSI and Shri Kamil Khan, Life Member FIGSI and office bearers of FIGSI and others.

They also visited various quarries in the Chamrajanagar region in a visit to learn about the cluster's skill development needs & potential.

Skill-led transformation reshaping the global stone industry



As the global stone industry embraces a new era of digital manufacturing and intelligent technologies, skill development has emerged as the critical driver of sustainable growth and competitiveness.

The integration of CNC machines, automation, and advanced tools is transforming the way stone is processed—but the true value of these innovations lies in the hands of a skilled workforce.

Industry data indicates that over 60% of stone companies worldwide are adopting digital tools, yet many face a significant skills gap.

Operating CNC routers, robotic polishers, digital scanners, and precision cutting machines requires technical training, digital literacy, and on-site application expertise. This makes upskilling and workforce development not just important, but essential to the industry's future.

JAIPUR SKILL CENTRE

Counselling Drive for FIGSI Skilling Program



Shri Rajeev Kumar, State Engagement Officer, NSDC Rajasthan during visit to Skill Development Centre of FIGSI at Jaipur, the Centre for Stone Excellence on 29 April, 2025.

As part of the admission process for the next batch at the FIGSI Centre for Stone Excellence, Jaipur, and the placements of the graduating candidates, a series of counselling and outreach sessions were conducted across various locations in Rajasthan.

These sessions aimed to raise awareness about career opportunities in the stone industry and guide prospective students on the value of

industry-aligned technical education. The sessions also highlighted the emerging career pathways in stone processing, design, quality control, and machine operation, especially in light of the industry’s increasing adoption of automation and digital technologies.

The Centre's hands-on training equips students with practical skills aligned to industry 4.0 standards, preparing them not only for immediate employment

but for long-term growth in a global industry. The initiative was led by Vivekananda Global University (VGU), FIGSI’s knowledge partner for the Skill Centres.

The Jaipur Centre has already trained and placed two successful batches, achieving 100% placement across reputed stone companies, a benchmark that highlights the centre’s strong industry connect and practical learning approach.



A New Age Of Growth

1130+

Candidates have applied for admission to the Centres

60+

Students have graduated from the Centres

100+

Participants at the first seminar at the Centre

5

Focussed courses to serve industry needs



INTEGRATED SKILL & RESEARCH CENTERS

Dedicated to the Stone Industry
2 Centers that set a new global benchmark



CSE
AT HOSSUR, TAMIL NADU



CSE
AT JAIPUR, RAJASTHAN



ABOUT FIGSI

A non-profit organization, FIGSI has been working for the benefit of the natural stone industry for the last 40 years. FIGSI works for technological advancement, policy improvement and for sustainable promotion of the stone industry. The Centers will provide trained manpower to the industry and will usher in a new era of growth.



OUR KNOWLEDGE PARTNER

Vivekananda Global University (VGU), Jaipur is a highly regarded private university that has been awarded an A+ grade by NAAC. This multidisciplinary university has been recognized as one of the top 6-25 private institutions in the country in ARIIA Ranking by the Ministry of Education, India. With its focus on quality education and research, VGU is committed to nurturing the next generation of leaders and innovators across a range of disciplines.

FOR MORE INFORMATION

- +91 80008 70766
- skill@figsi.in
www.figsi.in/skill
- FIGSIAI@vgu.ac.in

Account Executive Import and Export

- An account executive is a professional who acts as a vital link between a company and its customers. The responsibility is to strengthen customer relationships, generating new business opportunities and ensuring that customers' needs are met, thereby contributing to company revenue and growth.
- Import and export are two important aspects of international trade. Import means buying goods or services from another country, while export means selling your country's goods or services to another country.

Account Executive

There are many benefits of becoming an account executive. It not only helps you gain expertise in a particular business area but also gives you general commercial knowledge. Also, it opens up good job opportunities and a better salary.

Deep Understanding
of Business

Communication Skills

Problem Solving Skills

Personal
Development



Digital Marketing

- ✔ Digital marketing, also known as online marketing, includes all marketing efforts that currently use social media or the Internet to connect with potential customers. It is a dynamic field which has become essential for businesses of all sizes in today's technologically driven world.
- ✔ Learning how to use digital marketing is a must today. Compared to older marketing methods like radio, TV or print ads, digital marketing costs less and is much easier to plan, it's easier to implement and update. Plus, you can see how effective your strategy is and what types of marketing messages resonate with your audience.



Grow your business with digital marketing

Digital marketing is a great way to grow your business. It helps you reach millions of audiences, increase brand awareness and increase sales. Through digital marketing, you can better optimize your marketing strategies, this helps you reduce your marketing costs and increase returns.

Email Marketing

Search Engine Optimization

Google Business Profile

social media use



Computer Numerical Controller (CNC)

- ✔ Studying computer numerical control (CNC) offers many advantages, which can enhance both personal development and career opportunities. This technology is in high demand in manufacturing, engineering, and other related fields. Knowledge of CNC enhances your skills, prepares you for a career, and increases your success in the job market.
- ✔ CNC machines are used to produce high quality products for products that require precise fitting. CNC machines can be used to produce many good quality products, which includes aluminum, titanium, bronze, brass, stainless steel and many other metals with specific alloy contents.



CNC Why is it important?

CNC is commonly used in manufacturing by machining stone, wood, metal and plastic parts. Mills, lathes, routers, drills, grinders, water jets and lasers are common cutting tools whose operations can also be automated with CNC. It can also be used to control non-machine equipment such as welding, electronic assembly, and filament-winding machines.

Technical Understanding

career options

CNC router

3D printer



Mining Mate

Mining Mate Why is it important?

- ✔ Mining mates play a vital role in extracting minerals safely and efficiently. They manage various aspects of mining activities, such as ventilation, safety, and implementing mining procedures. Mining Mates are required to have valid certifications that demonstrate their skills and competence.

employment opportunities

skill development

social contribution

training and development



DGMS(Directorate General of Mines Safety)

The Directorate General of Mines Safety (DGMS) is the apex regulatory body responsible for maintaining and improving safety standards in mines in India.

The primary objective of DGMS is to protect the life and health of millions of workers employed in mines. It ensures that mine owners and management strictly adhere to safety rules and regulations so as to prevent accidents and occupational diseases.

BEIJING, CHINA



Stone Processing Machine Operator

- ✔ Stone processing machine operators run machinery to cut and shape stone materials, such as granite and marble, for a variety of applications such as tiles, building blocks, and facades. They ensure the correct size and finishing of the stones while adhering to technical specifications and safety regulations.
- ✔ Along with natural stone, the market for engineered stone is also experiencing significant growth due to its stability, durability and wide range of aesthetic options. Operators will need to be skilled in handling and processing these materials, which may have different properties and requirements than natural stone.



Stone Processing Operator Why is it important?

Stone Processing Operator is an important link in the stone industry. These skilled artisans transform raw stones into useful and beautiful products through various processes.

Stone processing operators play a vital role in the stone industry by transforming raw materials into valuable final products, maintaining quality, efficiently using resources and ensuring a safe work environment. Without their skills and expertise, construction, it will not be possible to produce high quality stone products for architecture and decoration.

BEIJING, CHINA

BALI, INDONESIA

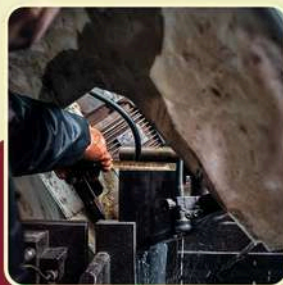

Fees Duration

Account Executive

1.5 Months Training	1 Months Job Training
Residential & Non Residential	
40000/-	25000/-

Digital Marketing

1.5 Months Training	1 Months Job Training
Residential & Non Residential	
40000/-	25000/-

CNC

1.5 Months Training	1 Months Job Training
Residential & Non Residential	
40000/-	25000/-

Mining Mate

3 Months Training	3 Months Job Training
Residential & Non Residential	
50000/-	30000/-

Stone Processing Machine Operator

3 Months Training	3 Months Job Training
Residential & Non Residential	
50000/-	30000/-

Salas Executive For Stone

1 Months Training	1 Months Job Training
Residential & Non Residential	
25000/-	15000/-

Get the right skills on your side.

Get in touch, get started

Corporates & employers

- Hire trained candidates for your business
- Sponsor trainings for your employees & staff
- Grant CSR as a mode of giving back to the society
- Get curriculum customised as per needs
- Provide on-job training and internship to trainees

Employees & youth

- Skill yourself to suit the industry requirements
- Programmes that provide placement
- Opportunity to begin industry internships

Entrepreneurship and incubation opportunities for start-ups



Revolutionising stone quarrying, processing and value-addition via skill upgradation and focussed scientific advancement.



TRIBUTE TO A GEM



R Sethuram

*A legacy of marvel
and innovation*

In the year 1940 Sri. R Sethuram started the Granite Business. The other contemporaries were Sri. Rao Bahadur Munivenkatappa and Sons, Mysore State Evershine Granites Kuppam Andhra Pradesh. Initially he started supplying curb stones, slabs, cobbles to UK. The first business was mostly in Grey Granite from Koira, Red Granite from Magadi and Black Granite from Kanakapura and Malur in Karnataka.

He took up several projects for supplying Granite to various Railway stations in Karnataka, Andhra and Maharashtra during 1950s and 1960s.

Sri. R Sethuram was invited for Tea by The Queen of England in 1955, in appreciation of supply of Grey Granite slabs and curbs stone for Trafalgar square in London. The stones can be found even today in Trafalgar square. He also took overseas projects and exported slabs & monuments to UK, USA, Italy, France and Germany between 1940 to 1960.

He was the main supplier of Grey and Red Granite stones for the



M/s Bharat Granite Private Limited was awarded with the gold medal for best exports in 1973 by Government of Mysore. The award was presented by Vice President of India Sri G S Pathak.

iconic project of Karnataka which was Vidhana Soudha in 1960s. For his contribution and dedicated efforts, he was felicitated by Sri Kengal Hanumanthiah, Chief Minister of Karnataka as the best supplier of stones for the construction of Vidhana Soudha during the opening ceremony in 1963.

He was also the supplier of black granite polished blocks to the prestigious Mahatma Gandhi Memorial at Raj Ghat, New Delhi. He also supplied black granite slabs to UCO bank head office in



Top: Shri R Sethuram at a Red Granite Quarry in Magadi. Above: Sri Sethuram started granite business in 1940.

All photos are from the family archives.

Calcutta and Magadi Red Granite polished slabs to RBI office in Madras in 1960s. Sri Sethuram travelled to many countries to understand the requirement and to promote the Indian varieties of stones during 1950s and 60s.

TRIBUTE TO A GEM

1940
Sri R Sethuram started his granite business

1955
Invited by The Queen of England in 1955 in appreciation of supply of stone for Trafalgar square in London

1960s
Main supplier of Grey and Red Granite stones for the Karnataka Vidhana Soudha

1966
First exporter of Black Granite dimensional blocks to M/s Kosan Trading Co, Japan

1973
M/s Bharat Granite Private Limited awarded with the gold medal for best exports in 1973 by Government of Mysore

1983
The family contributed to the formation of AIGSA in 1983, now known as FIGSI

Tracing Sri Sethuram's iconic contributions to the stone industry

Trafalgar square in London

He took overseas projects and exported slabs & monuments to UK, USA, Italy, France and Germany between 1940 to 1960.

Vidhana Soudha, Bengaluru

He was felicitated by Sri Kengal Hanumanthiah, then Chief Minister of Karnataka as the best supplier of stones for the construction of Vidhana Soudha during the opening ceremony in 1963.

Sri Sethuram was also the supplier of black granite polished blocks for the Mahatma Gandhi Memorial at Raj Ghat, New Delhi

He was the first exporter of Black Granite dimensional blocks from Dharmapuri, Tamilnadu to M/s Kosan Trading Co, Japan in 1966. He also introduced various colours of Granite like Chintamani Grey, Avalahalli Grey, Magadi Red, Black, granite from Dharmapuri, Mettur, Salem Tumkur porphyry and many more. M/s Bharat Granite Private Limited was also awarded the best exporter award by State and

Central governments in 1960, 1970 & 1980s.

He introduced new technology for polishing of Granite in India by Importing the first granite polishing machine from Scotland. He was very interested to introduce new varieties of Stones and he walked many kms in exploring the resources in tough terrains in states of Karnataka, Andhra

Pradesh, Tamilnadu, Maharashtra and Goa.

He founded several companies including M/s R Sethuram and Sons, M/s Hindustan Granite Exporting co, M/s Oriental select Granites Pvt Ltd, M/s Granites International, M/s Bharath Granite Pvt Ltd and M/s Prasad Granites during his life time. These businesses were continued by his sons Sri. S N Rao, Sri. S Subbarao and later by his grandsons Sri. S Rajnikanth and Sri. S Krishna Prasad.

The family also contributed to the formation of Association for Natural Stone Industry called AIGSA in 1983 now known as FIGSI and served for several decades to bring policy solutions to the Trade and Industry along with other stalwarts and office bearers of FIGSI.

A visionary and statesman, his contribution to the industry shall always be remembered in times ahead.

We from FIGSI pay our tribute to this great Icon who laid a firm foundation for the natural stone industry.



Three generations in one frame. Sri R Sethuram, his sons Sri SN Rao, Sri S Subba Rao and his grandson Sri S Rajni Kanth and Sri S Krishna Prasad seen with President of M/s Kosan Trading Co, Sri Hosano and Sri Taka Hoshi Japan.

DATA DEEPCDIVE

Global trade: Indian stone industry

1st Sep 2024 to 28th Feb 2025

India's Stone Trade Snapshot

- Exports dominate over imports across all categories, reaffirming India's position as a global leader in natural stone supply.
- Granite and marble show the highest export values, with quartz and sandstone trailing but still maintaining strong niche markets.
- India also imports marble heavily, particularly from Vietnam, Turkey, and Singapore, pointing to domestic demand for premium foreign varieties.

India is clearly an export powerhouse for granite, with limited dependence on imports. Export diversification is high with many small global buyers.

India's marble imports are substantial, suggesting demand for specialty or luxury variants. Meanwhile, Indian marble finds strong markets in the West and Central Asia.

India's sandstone exports are strong, especially to Europe. Imports are minimal and specialized – possibly for decorative or customized requirements.

The path ahead lies in value addition, smart manufacturing, and global collaboration.

Granite

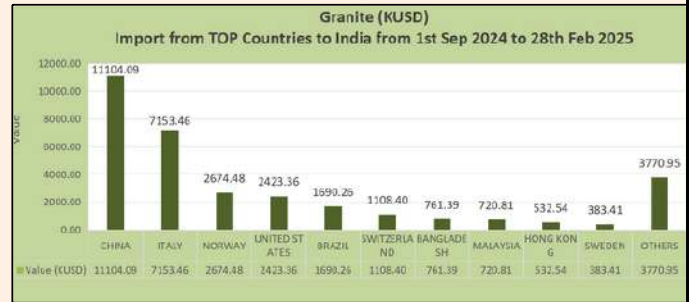

Marble

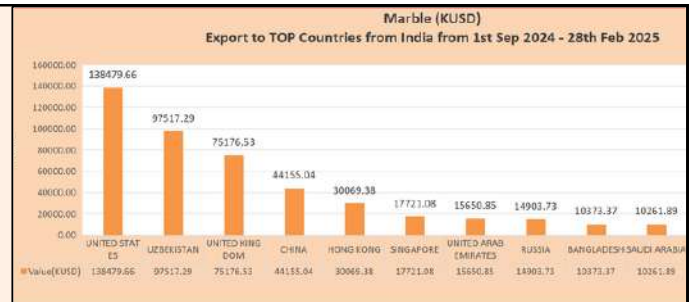

Sandstone



DATA DEEPIVE

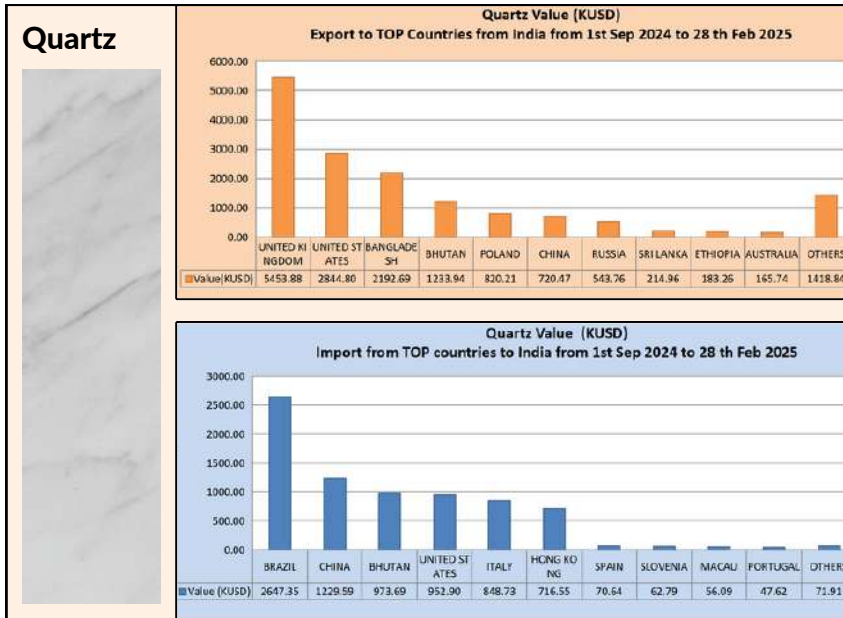

Quartz exports are modest but growing. Imports reflect demand for engineered quartz and niche applications, with Brazil as a clear leader.

India has strong bilateral slate trade – exporting to North America and importing from China/Russia – possibly for differing slate varieties or textures.

Key Trends & Takeaways

India as a Global Export Hub:

- India remains a leading exporter of granite, marble, slate, and sandstone.
- USA, UK, Russia, China, Vietnam are frequent trade partners across categories.

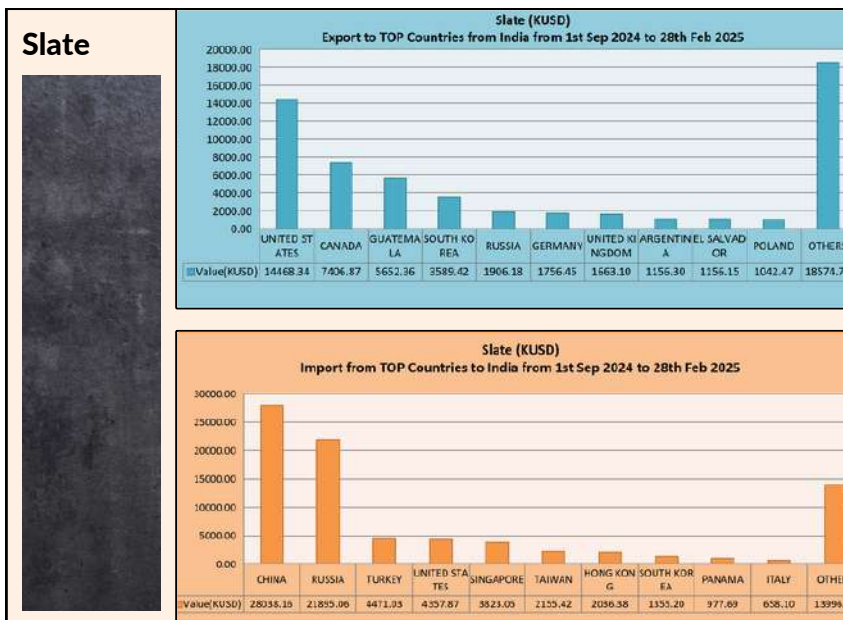

Imports Driven by Quality & Variety:

- Marble imports are particularly high from Vietnam, Turkey, and China, highlighting India’s appetite for variety or high-end finishes.
- Quartz and slate imports are relatively small but strategic.

Diversification & Opportunity:

- The strong “Others” category in exports (especially in granite and slate) suggests growing global reach beyond major traditional markets.
- Digital tools, automation, and sustainability practices could enhance India’s export competitiveness.



GLOBAL TRENDS

Shifting global dynamics in 2025 and its impacts on the Indian stone industry

Expert view: Stone business & world markets

FIGSI Vice President Mr Om Ashoken writes about global factors businesses should keep an eye on and how they can impact the stone market going forward.



Starting with United States

USA is important for the world since they are consuming around 15 % of the global production and several countries heavily dependent on US market . Due to this reason every country attaches greater importance on the health of the US economy, stability of US dollar and also concerned by US debt at present. USA is the NO 1 trading partner for India hence we are also equally concerned.

US Dollar

Until recently every central Bank of the world were keen to hold US Dollar as their reserve currency. But the safer haven status is shaken due to many factors. The predominant reason for the shift in perception is due to the weaponization of the Dollar, crashing its credibility. This move convinced many leading economics to reduce their dependence on Dollar and going after non-traditional currencies including Gold. EURO has gained more than 10% over USD in the last 3 months.

With this back drop comes RMB – Renminbi (Chinese Yuan) Digital RMB is a technological breakthrough with far reaching implications. For example, SWIFT, is the a global messaging system that facilitates secure and standardized communication between financial institutions for international payments, but it doesn't transfer money by itself, rather, it transmits payment instructions only.

Where as Digital RMB not only does messaging but also execute clearing and settlement of transactions in cross border RMB payments and trade. Hence it takes a more direct role in the whole financial process.

Now regarding US Debt

US debt to GDP is 125 % and total debt is 36 trillion out of which 42% held by private investors and 23% by foreign central banks. Around 3% of GDP is going out for interest payment alone that is more than a trillion dollar every year .

Due to many reasons like tariff threats, US monetary system credibility on line. Moody's down grade of US economy has influenced individuals and countries to dump US treasury bonds. Today 10 year bond yield is around 4.5% and 30 years at 5 % pushing the borrowing cost for US substantially so as their interest payments,

US Economy

Sound economy is of paramount importance for our Exports. Right now 50% of Monuments are exported to USA hence the health of the US economy is pivotal for our export business.

Uncertainty is the biggest enemy for prosperity and US importers are uncertain about their future and not placing orders on a regular basis like normal times. Also due to Tariffs, US public going to pay more, reducing their disposable income. US consumer sentiment index dropping to 53 clearly goes to prove the present on-going negative trend. Since our product is coming under discretionary buying, purchase decisions can be postponed, resulting in reduced off take for monument products.



GLOBAL TRENDS

Now EU

INDIA – EU free trade agreement is one of the largest trade deals of the world today.

With EU's suspension of preferential tariff treatment under the Generalised Scheme of Preferences (GSP) in early 2023, India now trades with the EU solely under the WTO's Most Favoured Nation (MFN) principle.

But a comprehensive FTA would provide India with far greater and long-term strategic advantages with reduced tariff and far superior market access. Also EU – India FTA may influence EU to take a more flexible approach on Non tariffs barriers like CBAM and EU-DR which will do world of good for the Indian exporting companies.

NOW Germany

German Economy has grown significantly than expected in Q1 2025 mainly due to the exports of frontloading ahead of US tariff.

Europe's biggest economy out performed Euro zone average growth rate but Germany PMI still below 50 .

Germany is going ahead with 500 billion euro infrastructure fund which will boost not only German economy but the entire Euro zone.

But many feel the successful business model of using cheap energy with high engineering skills should be sorted out to take Germany again to pole position.

But Aging population, high energy cost, huge labour shortage, shrinking car industry facing strong headwinds are some of the stumbling blocks still witnessed in German economy.

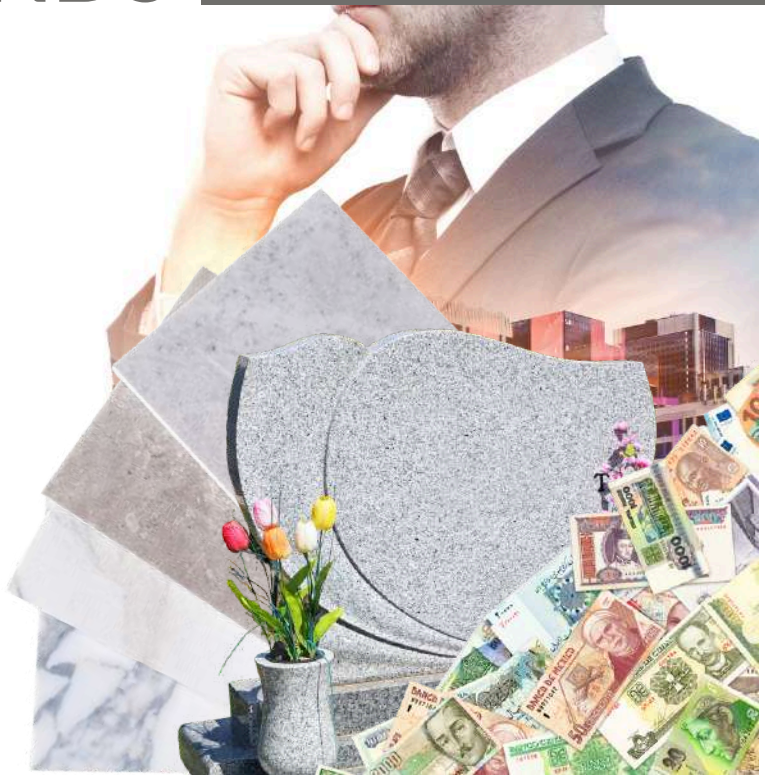

Now China

As a command economy China has made progress in many important fields and increasingly dominating new technology. China is trying to change the narrative of US on big tech, Currency and investment. The main difference between China and US is China a trade surplus country whereas USA carrying huge debts. But China is accused for exporting deflation to the rest of the world and also for their unfair trade practices.

Now India

Under the leadership of our dynamic and charismatic Honourable Prime Minister Shri Narendra Modi Ji, India has made Rapid strides in many key sectors, also one of the fastest and best performing economies in the world today. On purchasing power parity, we are already the 3rd largest economy in the world. India is highly respected since we are a robust, vibrant economy and important for the world at present.

India is well positioned and signed many trade deals like UAE, Australia, UK and India - EU trade deal to be concluded by year end has been taken on fast track and going for an early harvesting trade deal in July itself. Hence there are many great opportunities opening up for us in the coming months and years.

Let us hope for better tomorrow with more conducive geopolitical global environment leading to prosperity.



**Stone industry
pioneer since 1975**

HJS Granites Pvt Ltd

Global clients love us for our winning combination of new-age technology, efficient staff and dedication to quality. Our use of environment-friendly granite processing machinery compliments our passion for high-grade stones and customer satisfaction.



Quarries



Warehouse



Monuments plant



Gang saw & vertical plant



Shri Bhagwati Machines: Powering manufacturing through precision engineering

30 Years of Industrial Excellence – Since 1995

At Shri Bhagwati Machines Pvt. Ltd. (SBMPL), we are proud to have completed over three decades of shaping India's stone processing landscape. Established in 1995 by our visionary founder, Mr. Yashwant Sharma, we identified early the vast potential in the underexplored realm of industrial stone machinery.

What started in Ajmer, Rajasthan, as a focused effort toward precision manufacturing, has today become a symbol of innovation, reliability, and engineering excellence in the stone, crane, and sheet metal sectors.

Our foundation is built on deep market understanding, continuous R&D, and our unwavering belief that technology should simplify, speed up, and scale stone production for manufacturers everywhere.

Driving the Evolution of India's Stone Industry

We've witnessed firsthand the transition of the Indian stone industry from manual operations to automation-driven smart manufacturing. At SBMPL, we're not just

Over the years, our presence has expanded to 100+ cities in India and 10+ countries globally.

5000+

installations of single/multi cutters

1000+

line polishing machines

100+

laser cutting machines

2,000+

custom-built cranes

keeping pace with these global trends—we're leading the transformation.

By integrating PLC-based systems, CNC controls, AI-readiness, and energy-efficient motors, we're pushing the boundaries of what's possible in stone processing.

Today's stone manufacturers demand precision, speed, and profitability — and our machines are designed to deliver exactly that.

Our Technological Milestones: 5 Machines Powering the Industry Forward

We take pride in showcasing five of our flagship machines that reflect our commitment to precision engineering, operator efficiency, and output optimisation.

1. Thin MultiWire DF 2000

Precision Like Never Before. 0.5mm cut for Maximum Slabs.

Our Thin MultiWire DF 2000 is engineered to deliver unmatched precision and efficiency in marble and granite slab cutting. With a maximum cut size of 3.6 m (L) × 2.0 m (W) × 2.1 m (H) and an overall machine dimension of 8.1 m (L) × 5.1 m (W) × 6.8 m (H), it boasts a compact footprint—requiring over 30% less foundation area compared to traditional systems.

Designed for high-yield performance, its thin wire saws feature cutting grooves as fine as 0.5 to 0.7 mm, pushing the yield rate to an impressive 97%. The machine is capable of producing ultra-thin slabs under 10 mm, thanks to its vibration-minimizing design that reduces edge breakage during the cutting process.

High-precision processing technology prevents wire marks and enhances slab flatness, delivering a superior finish. Operating below 90 dB, the DF 2000 ensures a quieter, safer working environment. Furthermore, its adaptable grooving capabilities make it suitable for a wide range of slab thickness requirements—offering flexibility without compromising on quality or performance. Hence, DF 2000 is just the right choice for maximum revenue and minimal waste.



2. Line Polishing Machine (LPM)

Built for Shine. Engineered for Speed.

Our Line Polishing Machine (LPM) is designed for high-efficiency surface finishing with CNC Servo Control and an energy-regenerative system for reduced power use. It supports 2 to 4 optional calibration heads (6-brick satellite or roller type), dual-cutter edge trimming, and a German-made non-contact slab scanner for accurate profiling.

The machine handles granite up to 100 mm, marble up to 60 mm, and slabs up to 2200 mm in height. Polishing is done using Italian 6-brick heads for granite and Frankfurt plates for marble. An automatic vacuum system ensures smooth slab handling via a hydraulic trolley, with optional dual longitudinal trimming for precise edges. With 1000+ installations, our LPM is trusted by polishing units across India and beyond.



3. Metro B-21

*Built for Hard Density Granite.
Designed for Performance.*

The Metro B-21 is a high-performance multi-blade granite cutter featuring the world's first successful Dual RPM Spindle in a single housing—delivering twin output on a single shaft for maximum efficiency. Designed for hard-density granite, it boasts a robust U-shaped cast iron base for superior vibration damping. Its bridge motion is driven by Linear Motion Bearings and a Ball Screw System for smooth, precise positioning. A frictionless beam without wheel carriages reduces wear, while the servo-driven bridge ensures fast, accurate movement. Controlled by PLC and servo systems, it guarantees reliable performance. A multi-point stainless steel water shower and durable cutter guard ensure uniform cooling and extended blade life. Metro B-21 combines speed, precision, and durability—ideal for demanding granite cutting operations.

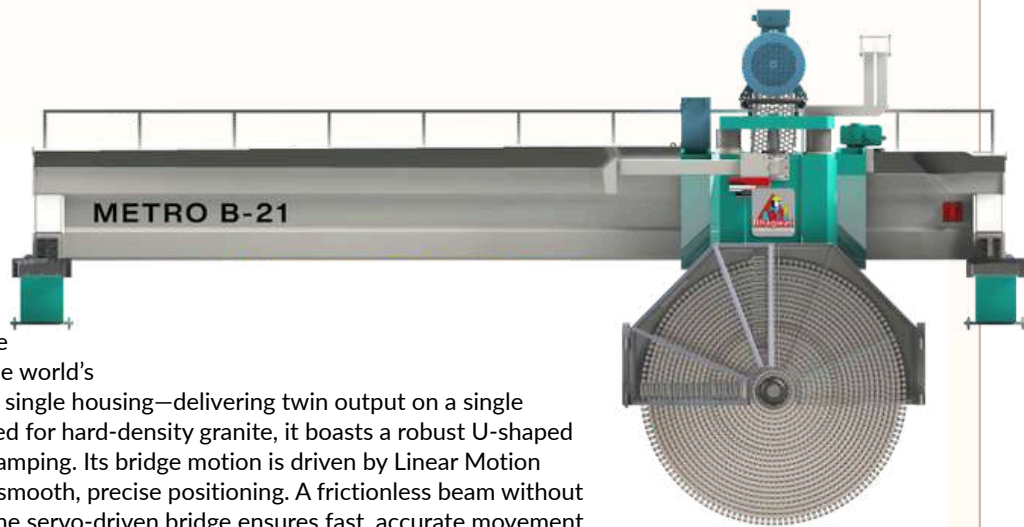

4. VersaWire Multiwire

Multiwire Precision for Maximum Output.

With VersaWire, we've developed a powerful and adaptable multiwire block cutting machine that delivers unmatched performance for high-volume stone processing.

VersaWire ensures exceptional productivity, minimal wastage, and precise slab output across a variety of stone types.

Equipped with a heavy-duty frame, intelligent wire tensioning system, and servo-controlled automation, the machine is capable of operating continuously with smooth, vibration-free performance. Whether handling dense granites or soft limestones, VersaWire guarantees consistent results, cut after cut. The system also features automatic lubrication, hydraulic control for wire pressure, and a quick-lock mechanism that reduces setup time and boosts machine uptime. Compatible with multiple wire diameters (from 4.3 mm to 7.3 mm), VersaWire meets the needs of both standard and customised plant operations.



5. ZX-1600 MonuMill

Monumental Cuts. Monumental Precision.

Our ZX-1600 MonuMill is a CNC bridge-type machining centre with 5/6 interpolated axes and a Z-axis stroke ranging from 800 to 2000 mm. It's designed for high-precision two- and three-dimensional milling, including columns, sculptures, and intricate monuments.

Capable of using diamond blades from 350 mm to 1000 mm and various diamond tools, it's an ideal solution for custom and large-format stonework—delivering power, precision, and adaptability in one intelligent system.



What's Next: Smarter Machines for a Sustainable Tomorrow

As the global industry moves toward eco-efficiency and intelligent automation, we at Shri Bhagwati Machines are committed to building smarter, greener, and more integrated systems.

What makes us different is not just our machinery, but our approach: end-to-end customer partnership. From machine recommendation and installation to training, maintenance, and upgrades—we are with our clients every step of the way.

Our roadmap includes:

- Energy-efficient motors
- Smart sensor-based fault diagnostics
- Water recycling systems
- AI-ready machine architecture



Shri Bhagwati Machines

- Visit: www.bhagwatimachines.com
- Contact: +91 88549 03444, +91 76656 31999
- Email: info@bhagwatimachines.com

EXPERT VIEW

India's Rise in Machinery & Tech from Europe to Self-Reliance

Technology in the granite and marble industry has transitioned gracefully over the decades and brought about changes in the industrial practises, globalisation and environmental awareness.

When I look back to the evolution of machinery in the stone industry, there is a sense of pride.

Back in the late 80's and early 90's pneumatic drills and wire saws began to replace manual tools at the quarries . The granite processing was slowly emerging as an extension to the industry, where gangsaw and polishing machines were replacing rudimentary hand polishing tools

The export market was slowly picking up. It was around this time that buyers from Italy and other European countries were entering India to buy granite and marble. While efficiency improved and there was a reduced dependency on labour with a better quality output, environmental degradation and safety issues persisted. With the entry of the European buyers, came the introduction of machinery that were imported from primarily Italy, companies like Breton SpA Tema Longinotti and Pedrini SpA were selling their machinery to India, and around 1997 , Italy was the largest exporter of processing machinery to India

The next ten years that followed, between 2000s to 2010 there was an export boom. A sudden surge in the international market. Technology was progressing and the use of advanced wire saws, diamond wire cutting and hydraulic drilling systems while quarrying were the modern methods used. The processing industry had progressed rapidly and CNC (computer numerical control)machines were now being used, enabling precise cutting and shaping. Automated polishing lines improved the finish and reduced the processing time. This was the time when the Indian Stone Industry was being recognised globally due to improved aesthetics at lower costs. Italian machines like Gaspari Menotti had well established their presence in the Indian Stone Industry by the early 2000's.



Sandhya Raghunandan
Red Graniti Quarries
& Blocks India Pvt Ltd,
Bengaluru

India was now competing in the international market. With higher productivity, consistency in quality and due to the advancement in technology in the processing sector, the Indian stone industry was able to provide value addition to the granite or marble.

Post 2010, the technology had further advanced to now addressing sustainable methods of mining like the water recycling systems, dust suppression and noise reduction technologies. There was also a great emphasis on zero-waste processing.

The integration of Italian stone processing machinery had been a game-changer for the Indian granite industry, enabling it to match global quality benchmarks and increase exports. Companies in Karnataka, Tamil Nadu, and Andhra Pradesh relied on Italian equipment for its innovation, durability, and efficiency.

There were many factors as to why the Italian machinery dominated the Indian Stone Industry during the two decades of progression:

- Superior technology: Italy, being a global leader in stone machinery (Breton, Pedrini, SIMEC, CMS), offered unmatched precision.
- Export requirements: European buyers demanded high finish, which Italian equipment delivered.
- Lack of Indian alternatives: Indian manufacturers lacked R&D in stone cutting/polishing until the late 2000s.

However post 2014, there was a gradual shift from the imported Italian technology and machinery to Indian manufacturers entering the market.

This notable transition from Italian to Indian machinery, was driven by cost, localization, and technological improvement in Indian manufacturing thanks to the "Make in India" campaign introduced in 2014 and later in 2020 the "Atmanirbhar Bharat" (a self reliant India) both encouraged by the present Government of India .

While "Make in India" focused on attracting foreign investment and promoting manufacturing, "Atmanirbhar Bharat" emphasized reducing dependency on imports, fostering innovation, and ensuring that India becomes a global leader in various sectors.

Tata Hitachi , Kobelco , Volvo, Larsen and Toubro to name a few started manufacturing excavators in India. Companies like the multinationals Sandvik and Sany started manufacturing in India catering to various tools and equipment required in the Indian Stone Industry.

Today, Indian manufacturers like Shri Bhagawati Machines Pvt Ltd , Rosava Engineering Pvt Ltd and many others have brought about a significant change in the choice of preferences for the Indian Granite and Marble Industry, and it is very clear that the Indian manufacturers have taken over the Stone Industry catering to almost every need of the customer be it in the mining or processing sectors.

The Indian granite industry has today evolved from being completely dependent on Italian machinery to confidently adopting homegrown technology.

What next? 2025 onwards

With Research and Development advancement and the need for a greener world , the Indian Stone Industry is certainly not left behind. We are already making a

significant change towards SMART Mining and Sustainability.

AI Driven technology for defect detection in blocks, to Drones used in Site Mapping. A Sustainable Environment is now growing in momentum in the Indian mindset and water conservation, recycling, waste management, quarry rehabilitation and land restoration are being introduced.

India's granite and marble industry is undoubtedly advancing to meet – and increasingly exceed – global standards. Our strides in adopting autonomous technologies and state-of-the-art machinery are enabling unmatched precision and quality. Equally significant is our growing commitment to sustainability, with eco-conscious practices becoming integral to operations across the sector. This progress has firmly instilled in me the belief that the Indian natural stone industry is not only self-reliant but also well-positioned as a globally competitive and responsible leader in the field.

Being witness to the entire transition in time from the early 90s to the present and hopefully the future, my belief lays strong and unwavering that the Indian Stone Industry stands tall in the global scenario.

Its journey of transformation, innovation, and self-reliance is a testament to the strength and potential we hold as a nation."

Union Cabinet approves Rs 8,800cr to boost Skill India Programme

The Union Cabinet approved continuation & restructuring of the 'Skill India Programme (SIP)' till 2026 with an outlay of Rs 8,800 crore from the period of 2022-23 to 2025-26. To keep pace with evolving industry demands and advent of new-age technologies, the Rs 6,000 crore PMKVY 4.0 scheme will provide over 400 new courses on AI, 5G technology, cybersecurity, green hydrogen and drone technology among others.

Skilling in Mining

Exporters set to get collateral-free loans

The commerce department on 30th May 2025 unveiled the elements of the Export Promotion Mission focused on providing low-cost and collateral-free loans, backing new instruments, supporting opportunities in new markets and boosting export credit to e-commerce, amid concerns that the overall allocation of Rs 2,250 crore was spread too thinly.

Top of the agenda is Niryat Rin Vikas or NIRVIK, an interest equalization scheme targeted at MSMEs and new exporters. The plan is to reset interest rates annually by bench marking them to rates in other countries that Indian exports are competing with.

BUSINESS NEWS

SC restrains Centre from granting ex-post facto environmental clearances in future

The Supreme Court on 16th May, while directing the Union government not to grant 'ex-post facto' Environmental Clearances (EC) in future, set aside the previous Office Memoranda and notifications which allowed for the grant of ex-post facto Environmental clearance for mining projects.

The order was passed by the Bench of Justice Abhay S Oka and Justice Ujjal Bhuyan. As per the verdict, the projects that commenced without obtaining the mandatory prior Environmental Clearance, could not be regularized by granting them EC in future. Reading out the operative portion of the judgment, Justice Oka said that there were no equities in favour of those who committed gross illegalities without obtaining prior ECs. Those who acted without ECs were not illiterates.

They were real estate developers, companies, mining industries, public sector undertakings, etc. Noting that the illegalities were committed on a voluntary basis, the Apex Court directed the Union of India not to come out with any version of the 2017 notification and the 2021 OM, along with all circulars, orders, and notifications issued to give effect to these notifications, and stuck them down.



SNIPPETS

More than 75,000 MSMEs shut shop in past five years: Govt

About 35,567 micro, small and medium enterprises (MSMEs) across India, which have registered on the central government's Udyam Portal, have shut down in the ongoing financial year (2024-25), as on February 28, 2025. In total, over the past five years, 75,082 MSMEs have shut down across the country. This is since the portal was launched on July 1, 2020.

K'taka ranks 11th on candidates trained under PMKVY

Karnataka comes up 11th among all the states and union territories in terms of the number of candidates trained under Pradhan Mantri Kaushal vikas Yojana (PMKVY), a scheme under the Skill India Mission, since its inception from 2015. As of December 31, 2024, 5.74 lakh youth from the state have been trained.

Boost to big-ticket projects in Bengaluru as B-SMILE takes shape

The State government has cleared the formation of Bengaluru Smart Infrastructure Limited (B-SMILE) a special purpose vehicle (SPV) aimed at executing major infrastructure projects in the state capital. The new SPV will commence operations with an initial corpus of Rs 7,000 crore, which has been assured in the state budget. The state government has cleared the formation of Bengaluru Smart Infrastructure Limited (BSMILE), a special-purpose vehicle (SPV) aimed at executing major infrastructure projects in the state capital.

Rajasthan govt big relief given to 18 thousand quarry license holders

Big announcement of the Mines Department in Rajasthan. Big relief given to quarry license holders. CM Bhajan Lal Sharma has taken a big step towards promoting zero waste mining, environmental protection and M-Sand along with giving big relief to quarry license holders. The Mines Department has reduced the mining plan fee for quarry license holders from 5 thousand to 3 thousand rupees regarding the budget announcement.

FIMI News Bulletin 1st May 2025

Rajasthan: Mining industry seeks new mineral tax to curb raw exports

Mining stakeholders in Rajasthan have urged the state govt to enact a new law which would impose a mineral tax of Rs 700 per tonne on raw mineral exports.

As the unchecked export of raw feldspar and quartz without value addition is adversely impacting the industry and leading to job losses, stakeholders have demanded the imposition of a mineral tax, similar to that in Jharkhand and Karnataka.

Surendra Singh Rajpurohit, coordinator of Rajasthan Minor Mineral Association, said, "In light of the Supreme Court's rederenced judgment, the organization has submitted suggestions for incorporation into the state's financial policy."

"This initiative aims to promote investment and significantly enhance the state's revenue in line with the spirit of Rajasthan First."

Karnataka Governor sends Bill to tax mineral-bearing land for President's nod

Governor Thaawarchand Gehlot on 28th March 2025 reserved the Karnataka (Mineral Rights and Mineral Bearing Land) Tax Bill for President Draupadi Murumu's assent, arguing that the proposed legislation would "transgress" Constitutional provisions and "adversely affect" another State.

Passed during the Belagavi session of the legislature in December, the Bill allows the government to levy taxes, with retrospective effect, on mineral rights and owners of mineral-bearing lands. This is estimated to fetch Rs 4,713 crore.

The government came up with the Bill following a Supreme Court ruling that states could collect taxes on mineral-bearing land and mining rights with retrospective effect from April 1, 2005. The proposed rate of tax under the Bill ranges from Rs 20 to Rs 100 per tonne for different minerals under all categories of mines.

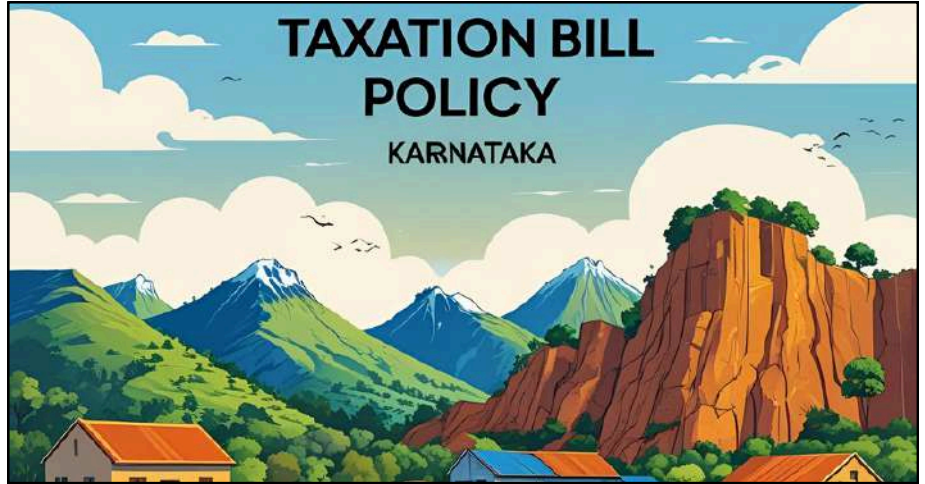

Gehlot said that the subjects of forests, mines and minerals are governed under central laws- the Forest Conservation Act, the Environmental Protection Act and the Mines and Minerals (Development and Regulation) Act. ".....there is an encroachment of State Legislature/Bill on the field occupied by the Parliament (sic)," Gehlot stated. "The Drective Principles of State Policy....clearly contemplates

and mandates that the ownership and control of the material resources of the community are so distributed to serve the common good, and the operation of the economic system does not result in concentration of wealth," Gehlot stated.

The Bill would have an impact on the three Central laws mentioned earlier.

Deccan Herald



BUHARIWALA LOGISTICS
Experienced Since 1925
ISO 9001:2015 / ISO 45001:2018 & AEO Certified Company
www.buhariwalasglobal.com



Buhariwala Logistics -
having served as a Logistics partner for
STONA exhibitions

CALL US
+91 9892503453
+91 9821010694/9821892645
email : intl@buhariwalasglobal.com/projects@buhariwalasglobal.com

www.buhariwalasglobal.com
Mumbai- Delhi-Bangalore-Chennai- Nagpur-Ahmedabad

Jharkhand hikes cess on mined minerals up to four times

The Jharkhand government on 12th March decided to hike the cess on mined minerals up to four times to boost the state's revenue, an official said. The proposal was approved during the cabinet meeting chaired by Chief Minister Hemant Soren.

"The cess on coal for per metric tonne dispatch was increased to Rs 250 from the existing Rs 100, while the same on iron ore was hiked to Rs 400 from the existing Rs 100," cabinet Secretary Vandana Dadel said.

INDUSTRY NEWS

Shri R Veeramani elected CAPEXIL Vice Chairperson, Stone Panel Chairman

Shri R Veeramani, Founder President of FIGSI, has been elected as Vice Chairperson, CAPEXIL & Panel Chairman, Natural Stone and Products Panel.

With over five decades of experience, Shri Veeramani has been a transformative figure in the stone sector. His appointment reflects a seamless alignment of industry insights & policy expertise.

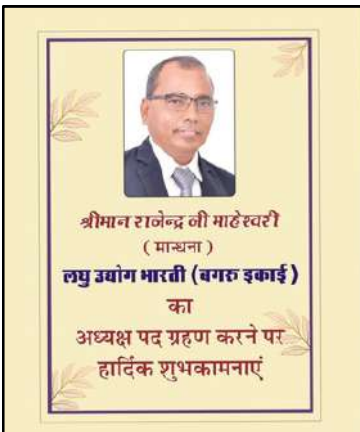

Shri Rajendra Maheshwari appointed President of Laghu Udyog Bharathi, Bagru

Shri Rajendra Maheshwari has been appointed as the new President of Laghu Udyog Bharathi (LUB), Bagru, Rajasthan.

Laghu Udyog Bharathi is a prominent non-governmental organization focused on empowering micro, small, and medium enterprises (MSMEs) through advocacy, policy support, and capacity-building initiatives.

Under Maheshwari's stewardship, the Bagru unit is expected to intensify partnerships with governmental agencies and industry bodies. Maheshwari assumes office at a crucial time, with LUB focused on driving Make-in-India initiatives and grassroots industrial development.

Congratulations and best wishes to Shri Rajendra Maheshwari on his appointment!

Iron Man races to the World's Highest Peaks



Saurabh Bhasin is an accomplished endurance athlete and mountaineer who translates the lessons of grit learned in ultramarathons and Iron man races to the world's highest peaks.

A veteran of demanding mountain ultramarathon events such as the Tahoe 200, his philosophy of "Showing Up" was forged through relentless preparation, including over 500 ascents of his local training ground, Mission Peak.

This unique foundation proved essential in his quest to climb the Seven Summits, a journey that has taken him from a challenging traverse of Aconcagua to the summit of Mount Everest in May

2025, marking his sixth of the seven continental peaks.

He lives in Santa Clara, California and you can follow him on Instagram at [@mtn_runr](https://www.instagram.com/mtn_runr).

The Seven Summits are the highest mountains on each of the seven continents, and climbing all of them is a major achievement in the world of mountaineering.

They include Mount Everest in Asia, Aconcagua in South America, Denali in North America, Mount Kilimanjaro in Africa, Mount Elbrus in Europe, Mount Vinson in Antarctica, and Puncak Jaya (Carstensz Pyramid) in Oceania.

NOTIFICATIONS

Government Extends Tenure of Granite and Marble Development Council Till 2030

No.1/17/2015-M.VI
Government of India
Ministry of Mines

New Delhi, the 19th June, 2025

ORDER

In continuation of this Ministry's orders of even number dated 23.04.2021 and 18.07.2024, it has further been decided, with the due approval of the Hon'ble Minister of Coal & Mines, to extend the tenure of the Granite and Marble Development Council for a further period of five years from 25.04.2025 to 24.04.2030 in order to prescribe a uniform framework for the systematic and scientific exploration of granite and marble minerals across the country. The composition and Terms of Reference (ToR) of the Council will remain the same. The Council may co-opt any other Member as it deems appropriate.



(Dinesh Mahur)
Joint Secretary to the Government of India
Tele No-011-23384334
Email: dinesh.mahur@nic.in

The Ministry of Mines, Government of India, has officially extended the tenure of the Granite and Marble Development Council for a further five-year term, from April 25, 2025 to April 24, 2030.

Approved by the Hon'ble Minister of Coal & Mines, this extension aims to ensure the continued systematic and scientific exploration of granite and marble resources across the country.

The composition and Terms of Reference (ToR) of the council will remain unchanged, with flexibility to co-opt additional members if needed.

RoDTEP Restored for AAs, SEZs, and EOUs

In a major relief to exporters, the Directorate General of Foreign Trade (DGFT), under the Ministry of Commerce & Industry, has announced the restoration of the RoDTEP (Remission of Duties and Taxes on Exported Products) scheme for Advance Authorisation (AA) holders, Special Economic Zones (SEZs), and Export-Oriented Units (EOUs), effective from June 1, 2025.

The move ensures that support under the RoDTEP scheme is now extended to products manufactured in these units. Newly aligned HS codes as per the Finance Act, 2025, are detailed in Appendix 4RE on the DGFT portal under 'Regulations > RoDTEP'.

This policy change is expected to enhance India's export competitiveness by reducing cost burdens on exporters & encouraging value-added manufacturing within these special categories. It also addresses industry demands to include all major export-linked production units under RoDTEP, fostering ease of doing business and greater policy consistency.

Government of India
Ministry of Commerce & Industry
Department of Commerce
Directorate General of Foreign Trade
Vanijya Bhawan, New Delhi

Notification No: 11/2025-26
New Delhi, 26 May, 2025

Subject: Restoration of RoDTEP for Advance Authorisations (AAs) holders, Special Economic Zones (SEZs) and Export-Oriented Units (EOUs) from 01.06.2025

S.O.(E): In exercise of the powers conferred by Section 5 of the Foreign Trade (Development and Regulation) Act, 1992, read with Para 1.02 of the Foreign Trade Policy 2023, the Central Government hereby notifies the restoration of RoDTEP for Advance Authorisations (AAs) holders, Special Economic Zones (SEZs), and Export-Oriented Units (EOUs) from 01.06.2025.

2. The rates are available in Appendix 4RE including newly aligned HS codes as per the Finance Act, 2025. The details are available on the DGFT portal at www.dgft.gov.in, under the link 'Regulations > RoDTEP'.

Effect of this Notification: The Support under the RoDTEP Scheme for exports of products manufactured from AAs, SEZs, and EOUs is restored with effect from 01.06.2025.

This issues with the approval of the Minister of Commerce & Industry.

(Ajay Bhadoo)
Director General of Foreign Trade
Additional Secretary to the Government of India
E-mail: dgft@nic.in

[Issued from File No.: 01/94/180/019/AM26/PC-4]

NOTIFICATIONS

Andhra Pradesh Unveils Minor Mineral Policy '25

GOVERNMENT OF ANDHRA PRADESH
ABSTRACT

MINES & MINERALS - Andhra Pradesh Minor Mineral Policy 2025 - Orders
- Issued.

INDUSTRIES & COMMERCE (M.II) DEPARTMENT

G.O.Ms.No.57

Dated: 18.04.2025

Read the following:

1. G.O.Ms.No.11, Ind. & Com. (M.III) Dept., dated:11.02.2020.
2. G.O.Ms.No.21, Ind. & Com. (M.III) Dept., dated :25.03.2021.
3. G.O.Ms.No.65, Ind. & Com. (M.III) Dept. dated:04.08.2021.
4. G.O.Ms.No.71, Ind. & Com. (M.III) Dept. dated:22.10.2021.
5. G.O.Ms.No.8, Ind. & Com. (M.III) Dept. dated:16.02.2022.
6. G.O.Ms.No.13, Ind. & Com. (M.III) Dept. dated:14.03.2022.
7. G.O.Ms.No.14, Ind. & Com. (M.III) Dept. dated:14.03.2022.
8. G.O.Ms.No.25, Ind. & Com. (M.III) Dept. dated:06.04.2023.
9. From the Commissioner & Director of Mines & Geology, AP, single e-file bearing Comp No.2711508, dt.18.03.2025.

ORDER:

In the reference 1st read above, Government have issued orders revising the rates of Seigniorage Fee payable by all the minor mineral lease holders in the State. Vide reference 2nd cited, orders were issued to levy consideration amount on minor mineral leaseholders, in addition to Seigniorage Fee, DMF & MERIT, @ 50% of Seigniorage Fee for Granite and one time of Seigniorage Fee for all Minor Minerals except Granite

2. Government vide references 3rd to 8th read above have issued orders introducing various amendments to the APMMC Rules, including the introduction of premium amount for grant of leases, making all applications filed for grant of leases ineligible, introduction of auction system for grant of leases in Government lands, enhancement of Security Deposits, and prescription of payment of 10 times of Annual Dead Rent for grant of renewals

3. In the reference e-file 9th read above, the Commissioner & Director of Mines & Geology, AP submitted that the mining sector plays a significant role in supporting the State's economy and livelihoods. He informed that various stakeholders have submitted representations during consultations, highlighting the need for facilitative measures to promote sectoral growth and enhance ease of doing business. These include rationalization of upfront premium amounts, one-time opportunity for applications filed before the auction regime, revisiting the consideration amount, and a streamlined framework for renewals.

4. In this context, and in line with the recommendations of the Ministry of Mines, Government of India, as well as inputs from benchmarking of the policies of various other States, the Commissioner & Director of Mines & Geology has proposed a

Cont...2

NOTIFICATIONS

Andhra Pradesh Unveils Minor Mineral Policy '25

comprehensive and forward-looking Andhra Pradesh Minor Mineral Policy 2025. The proposed policy aims to foster responsible mining, attract investments, ensure sustainable practices, and further position the sector as a key contributor to economic growth and employment generation in the State.

5. After careful examination of the proposal submitted by the Commissioner & Director of Mines & Geology, AP vide reference 9th read above, Government hereby introduce the Andhra Pradesh Minor Mineral Policy 2025 and order to introduce the changes to exiting rules and regulations accordingly. The Policy Document under Annexure is appended to this order.

6. The Commissioner & Director of Mines & Geology, AP., shall submit proposals for necessary amendments to Andhra Pradesh Minor Mineral Concession Rules, 1966, Andhra Pradesh Minor Mineral Auction Rules 2022 and any other orders required in this regard at the earliest to take necessary further action accordingly in the matter.

7. This order issued with the concurrence of the Finance Department vide U.O.No. FIN01-FMU0ASD(IC)/6/2025 (Computer No. 2791215), dt.14.04.2025

(BY ORDER AND IN THE NAME OF THE GOVERNOR OF ANDHRA PRADESH)

PRAVIN KUMAR
SECRETARY TO GOVERNMENT (MINES)

To
The Commissioner & Director of Mines & Geology, Ibrahimpatnam, NTR District.

Copy to:

The Finance (FMU, I&C, I&I & Energy) Department.

The Law Department.

The PS to Spl. CS to CM.

The OSD to Minister(M&G).

The PS to Secy. to Govt.(M).

SF/SCs.

// FORWARDED : : BY ORDER //

SECTION OFFICER

NOTIFICATIONS

DGFT Introduces 'Mode of Export of Services' Field in eBRC Format to Enhance Data Accuracy

Government of India
Ministry of Commerce & Industry
Department of Commerce
Directorate General of Foreign Trade

Vanijya Bhawan, New Delhi - 110 011
Date: April 21, 2025

Trade Notice No. 02/2025-26

To,

1. All Exporters/Members of Trade & Industry
2. All Banking and Financial institutions
3. All Export Promotion Councils/Commodity Boards
4. All DGFT Regional Authorities

Subject: Introduction of 'Mode of Export of Services' Field in eBRC Format for Services Exports with effect from May 01, 2025 - regarding.

Reference is invited to Trade Notice No. 12/2024-25 dated August 14, 2024 and Trade Notice No. 33/2023-24 dated November 10, 2023. This Directorate has enhanced the online self-certification process for Electronic Bank Realisation Certificates (eBRCs), enabling exporters to self-certify export realisations directly on the DGFT portal via API integration or bulk upload functionality.

2. In this regard, attention is drawn to Foreign Trade (Development & Regulation) [FTDR] Act, 1992, Chapter 1, Para 2, Sub-para (j) which states that, - "services" means service of any description which is made available to potential users and includes all the tradable services specified under the General Agreement on Trade in Services entered into amongst India and other countries who are party to the said Agreement: Provided that, this definition shall not apply to the domain of taxation;

2.1. The given service export classification nomenclature is also defined in the General Agreement on Trade in Services (GATS) of the World Trade Organization (WTO).

3. Accordingly, this Directorate is **introducing a new field titled 'Mode of Export of Services' in the eBRC format** for the Services Export category, applicable for eBRC generated on or after May 01, 2025. Exporters certifying eBRCs linked to IRMs will be required to indicate the relevant mode of export of service while completing the certification. The inclusion of this field is aimed at improving the granularity and

accuracy of services export data. This reform also aligns India's data capture policy with international norms under WTO GATS.

4. This new field - 'Mode of Export of Services' - corresponds to the four modes of services trade which have been mentioned under GATS, namely:-

Mode	Definition	Example Services
Mode 1: Cross-Border Supply	Services supplied (from India) remotely across borders without movement of individuals.	IT services, remote consulting, telemedicine
Mode 2: Consumption Abroad	Consumer travels to the service provider's country (i.e. to India)	Tourism, medical treatment in India, foreign students
Mode 3: Commercial Presence	Service supplier (from India) establishes a commercial entity abroad.	Indian bank branches overseas, IT company subsidiaries
Mode 4: Presence of Natural Persons	Individual (from India) travels abroad temporarily to provide services.	Engineers, doctors, IT professionals on assignment

5. Help manual & Feedback:
User Manuals may be accessed on the DGFT website under the 'Learn' section (Application Help and FAQs -> eBRC). Stakeholders are also encouraged to provide their feedback via email to ebrc-dgft@gov.in

6. Support Channels:
For assistance, exporters may contact the DGFT Helpdesk through the toll-free number or raise a service ticket via the DGFT website under Services -> DGFT Helpdesk Service.
This Trade Notice is issued with the approval of the competent authority.

(Md. Moin Afaq)
Joint Director General of Foreign Trade
E-mail: afaq.moin@gov.in

(Issued from File No.: 01/02/74/AM-24/EG&TF)

The Directorate General of Foreign Trade (DGFT) has introduced a new field titled 'Mode of Export of Services' in the Electronic Bank Realisation Certificate (eBRC) format, applicable from May 1, 2025, to improve classification and reporting of service exports.

This move aligns with global WTO-GATS standards, ensuring better alignment with international norms for cross-border trade in services.

The four designated modes of services export are:

1. Cross-Border Supply (e.g., remote IT services)
2. Consumption Abroad (e.g., medical tourism)
3. Commercial Presence (e.g., Indian firms abroad)
4. Presence of Natural Persons (e.g., engineers on overseas assignments).

This granular classification will enable better tracking of India's services export performance and help design more effective export promotion schemes.

It also supports evidence-based policy-making, particularly in rapidly growing sectors like IT, healthcare, education, and professional services.

The DGFT has provided learning resources and FAQs under the 'Learn' section of its portal to help stakeholders understand the update.

Exporters may also seek assistance via the DGFT Helpdesk or by writing to the designated support email (ebrc.dgft@gov.in).

MUSICAL QUARRY

Quarry turns concert venue

On May 10, 2025, Adriatique, a Swiss electronic music duo, held a concert called "X" at the Dionysos Marble Quarry in Athens, Greece.

The quarry, located just outside Athens, was transformed into a futuristic cathedral of sound for the event. The event was produced by FOR303 and was described as a "once-in-a-lifetime collision between nature, architecture, and music".

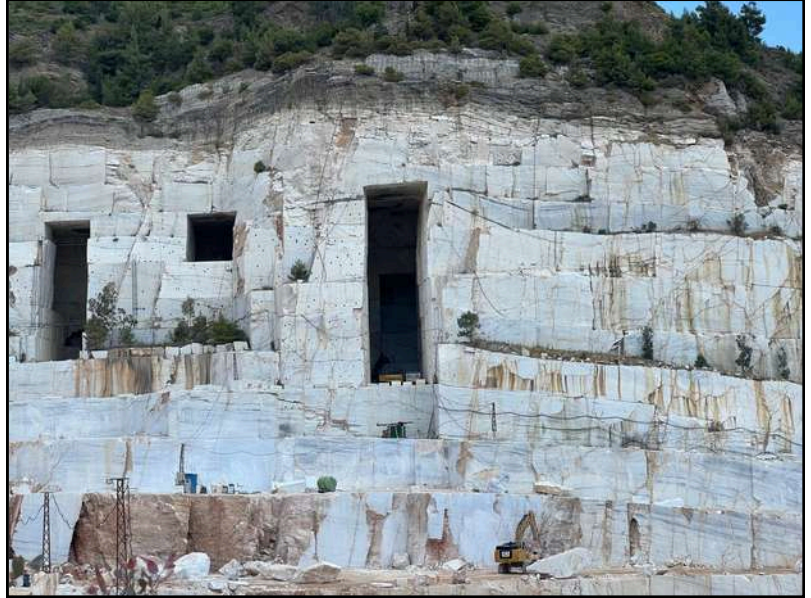

Obituary



Shri Thiru C RAMASWAMY

Passed away on 26-04-2025
M/s. Shakti Enterprises Attur
Life Member, FIGSI



Shri Parag Mehta

Passed away on 04-05-2025
M/s. Mehta Export House, Haryana
Life Member, FIGSI



Shri Dilip Bagla

Passed away on 02.06.2025
F/o Nishant and Kunal Bagla
Life Member, FIGSI

Obituary



Mr Shubh Modi & Ms Shagun Modi
Passed away on 12.06.2025
Mr Sanjeev Modi, Life Member, FIGSI lost his kin



Late Sri Parasmalji Chopra
Passed away on 19.06.2025
Father of Shri Goutham Chopra, FIGSI EC Member
M/s. Natural Granites, Bengaluru, Karnataka

Khajuraho Temples: A Sandstone Legacy

Nestled in Madhya Pradesh, the Khajuraho Group of Monuments is a UNESCO World Heritage Site celebrated for its stunning sandstone carvings and intricate temple architecture. The temples are divided into three groups: Western, Eastern, and Southern and are known for their elaborate sculptures depicting daily life, spiritual teachings, and artistic excellence. The sandstone used allowed artisans to achieve an extraordinary level of detail.

85 Number of temples said to be built originally

6 square km Approximate site area of the temple complex

25 Number of temples that survived

Buff and pink sandstone sourced from Panna region has been used to build the temples.

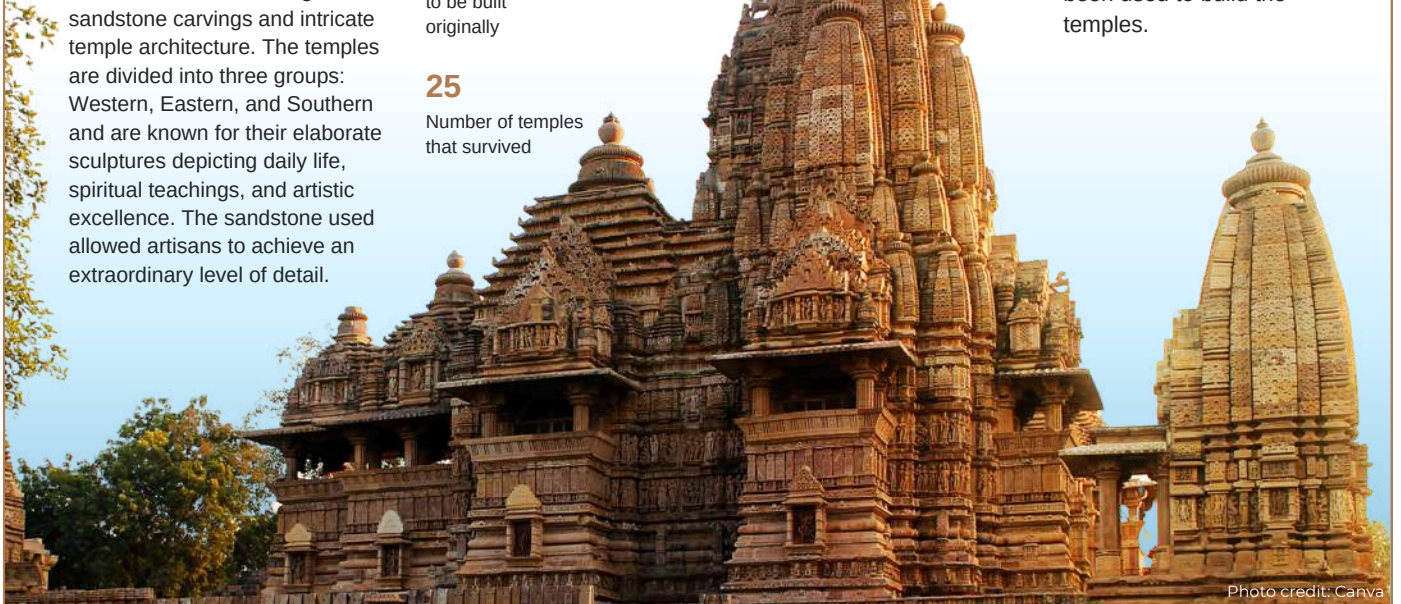

Photo credit: Canva

La Sagrada Família: Stone Art

Located in Barcelona, Spain, the Basílica de la Sagrada Família is an iconic example of architectural fusion and symbolic stonework designed by Antoni Gaudí.

The use of locally quarried Montjuïc sandstone reflects Gaudí's deep respect for regional materials, while more recent additions use reinforced stone panels and CNC-cut stone blocks. The fusion of organic forms, symbolic carvings, and

1882 The year when construction began

2030 Estimated year of completion

4.5 million Estimated annual visitors who come to the iconic structure

18 Towers planned of which 11 have been completed

Stones used:
Montjuïc sandstone, granite and basalt



Photo credit: Canva

QUIZ TIME!!!

1. What type of stone is 'Kota Stone'?
a) Slate b) Limestone
c) Granite d) Sandstone



2. Which of the following is NOT a variety of natural stone used in construction?
a) Granite b) Slate
c) Quartzite d) Graphite

3. What kind of laser technology is increasingly used to scan and map quarries?
a) LiDAR b) GPS
c) X-ray d) UV mapping



4. What is the advantage of using multi-wire saws over traditional gang saws?
a) They are lighter b) Fast & reduce waste
c) Less noise d) Only for small-scale

5. Which Indian cities are home to the FIGSI Centres for Stone Excellence?
a) Delhi & Mumbai b) Hosur & Jaipur
c) Udaipur & Chennai d) Bangalore & Patna



Answers
1. b) Limestone; 2. d) Graphite; 3. a) LiDAR; 4. b) Fast & reduce waste; 5. b) Hosur & Jaipur

30 YEARS OF EXCELLENCE



NEW LINE POLISH MACHINE MONOLITH

Transforming surfaces, elevating expectations of high-performance
Line polishing for unmatched clarity and luster



MONUMILL ZX-1600

Where blocks become *masterpieces* precision
Engineering for unparalleled stone transformation.



MULTI WIRE VERSAWIRE

Where technology meets opportunity. Unlock new
revenue streams and drive business growth with
our advanced granite cutting solutions.

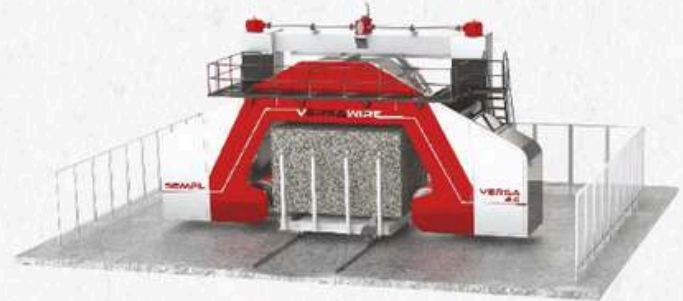

METRO B-21

METRO B-21

Multi-blade granite block cutters -
DUAL RPM single housing technology

SHRI BHAGWATI MACHINES PVT. LTD.

END-TO-END TURNKEY SOLUTIONS INNOVATIVE SOLUTIONS GLOBAL REACH ROBUST GLOBAL SUPPLY CHAIN ENHANCED EFFICIENCY 24/7 SERVICE

sales.smd@bhagwatimachines.com | CONTACT US :- +91 8690131999 Follow Us On | Visit Us : www.bhagwatimachines.com

G-179 Makhapura Extension Parbatpura, Makhapura Industrial Area, Ajmer, Rajasthan 305002



Your navigator to the world of stone.

**Bangalore International
Exhibition Centre, BIEC,
Bengaluru, India**



**Federation of Indian Granite
and Stone Industry**

www.figsin.in | www.stonaindia.co.in
figsi@figsin.in | stona@figsin.in

**Grow with the
robust Indian
stone industry.**



Scan this QR code to
stay updated with
the latest news and
initiatives from FIGSI
& STONA.